

**B.Tech 1st Semester Exam., 2019
(New Course)**

ENGINEERING GRAPHICS AND DESIGN

Time : 3 hours

Full Marks : 70

Instructions :

- (i) The marks are indicated in the right-hand margin.
- (ii) There are **NINE** questions in this paper.
- (iii) Attempt **FIVE** questions in all.
- (iv) Question No. 1 is compulsory.

1. Choose the correct answer of the following
(any seven) : 2×7=14

(a) The size of A5 drawing sheet recommended by the Bureau of Indian Standard is for

- (i) 148 mm × 210 mm
- (ii) 210 mm × 297 mm
- (iii) 297 mm × 420 mm
- (iv) 420 mm × 594 mm

(b) Continuous thin with zigzag line is used for

- (i) dimension line
- (ii) long break line
- (iii) hatching
- (iv) All of the above

(c) In a scale, a line of length 2 cm is drawn on the drawing sheet to represent an actual length of 1 m. The representative fraction (RF) value is

- (i) 1 : 50
- (ii) 1 : 2
- (iii) 1 : 10
- (iv) 100 : 1

(d) In third angle projection method

- (i) object is placed in between the observer and the projection plane
- (ii) observer is in between the object and the plane
- (iii) projection plane is in between the observer and the object
- (iv) None of the above

(e) Side view is projected on the

- (i) profile plane
- (ii) horizontal plane
- (iii) vertical plane
- (iv) None of the above

(f) If a point is behind the VP and on the HP

- (i) front view will be above reference line
- (ii) front view will be below reference line
- (iii) top view will be above reference line
- (iv) None of the above

(g) The FV of a line is in true length and TV as point, if the line is

- (i) parallel to HP and inclined to VP
- (ii) parallel to VP and perpendicular to HP
- (iii) parallel to both HP and VP
- (iv) inclined to both the planes

(h) Symbol used showing the diameter in dimensioning is

- (i) ϕ
- (ii) ρ
- (iii) θ
- (iv) None of the above

(i) The locus of a point maintaining a constant radial distance from a fixed arc is

- (i) a parabola
- (ii) an ellipse
- (iii) a concentric arc
- (iv) a circle

(j) TV of a square plane parallel to HP and perpendicular to VP is

- (i) square
- (ii) point
- (iii) triangle
- (iv) hexagon

2. A point Q is situated in first quadrant. It is 40 mm above HP and 30 mm in front of VP. Draw its projections and find its shortest distance from the intersection of HP, VP and auxiliary plane. 14

3. A line AB , 80 mm long, makes an angle of 60° with HP and lies in an auxiliary vertical plane (AVP), which makes an angle of 45° with the VP. Its end A is 10 mm away from both the HP and VP. Draw the projections of AB and determine (a) its true inclination with the VP and (b) its traces. 14

4. Draw a rhombus of diagonals 100 mm and 60 mm long, with the longer diagonal horizontal. The figure is the top view of a square of 100 mm long diagonals, with a corner on the ground. Draw its front view and determine the angle which its surface makes with the ground. 14

5. Draw the projections of a cube of 25 mm long edges resting on HP on one of its corners with a solid diagonal perpendicular to the VP. 14

6. A solid hexagonal prism of 35 mm base sides and axis 70 mm long has a circular hole of 50 mm diameter, drilled at its mid height. Draw the development of lateral surface of the solid with hole. 14

7. A cone of base diameter 60 mm and altitude 80 mm rests on its base on the HP. It is sectioned by a vertical section plane parallel to VP passing through a point 10 mm in front of the axis. Draw the sectional front view. 14

8. Consider the parabolically blended curve defined by the points $P_1[0\ 1\ 0]$, $P_2[2\ 3\ 0]$, $P_3[4\ 1\ 0]$, $P_4[5\ 2\ 0]$. Rotate this curve about the x -axis through 2π to obtain a surface of revolution. Calculate the surface point at $t = 0.5$, $\phi = \pi/3$. 14

9. Isometric view of an object is given below :

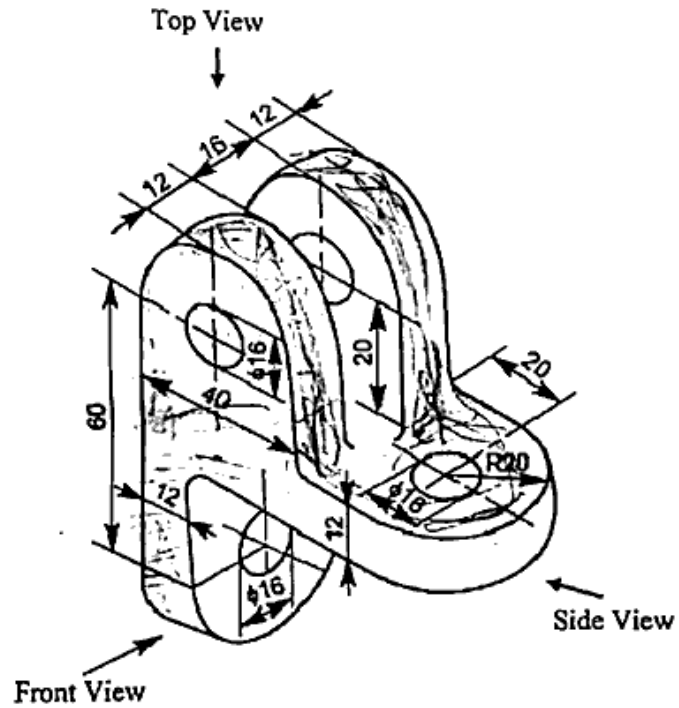

Draw three views of this object by first angle projection method.

14

<http://www.akubihar.com>

Whatsapp @ 9300930012

Your old paper & get 10/-

पुराने पेपर्स भेजे और 10 रुपये पायें,

Paytm or Google Pay से

<http://www.akubihar.com>